



## PRODUCT SPECIFICATION

---

AMENITY EXTERIOR - GRILLE



---

## INTRODUCTION

---

The Amenity Exterior Grille is manufactured with a tough and durable die cast aluminium housing and injection moulded polycarbonate diffuser that is suited a wide range of internal and external applications whilst maintaining an attractive and modern appearance in three colour options. With options including 1500, 2000 and 3000lm outputs, integral lithium emergency and a wide range of dimming types the Amenity Exterior is easily specified to suit a wide range of applications.

The Amenity Exterior includes premium mid power LEDs offering excellent efficiency and longevity with a lifetime of L90 at 60,000 operating hours. Energy savings can be further enhanced with a selection of integral presence detection and bright out microwave sensors including on / off, bi level dimming and wireless variants allowing luminaires to be grouped for simultaneous operation.

- CE
- IP65
- IK08
- L90 / 60K OPERATING HOURS
- 3 STEP MACADAM ELLIPSE

---

## APPLICATION

---

- Canteen
- Commercial/Offices

- Corridor
- Education
- Exterior
- Healthcare/Social Housing
- Hotel/Leisure
- Industrial/Manufacturing
- Parking/Exterior
- Retail
- Stairwell
- Store Room
- Toilet
- Transport
- Warehouse/Storage

---

## SPECIFICATION

---

### CONSTRUCTION

- Housing: High pressure die cast aluminium
- Finish: Matt black
- Finish: Matt white
- Finish: Matt grey
- Diffuser: Injection moulded high transmission opal polycarbonate
- IK08
- IP65

### PERFORMANCE

- Part L2 compliant
- 3SCDM Three step Macadams ellipse
- TM21: L90 at 60,000 operating hours
- Up to 90 luminaire lumens per circuit Watt.

### EMERGENCY

- Available with optional standard, self test and autotest integral emergency with lithium batteries for extended warranty and lifetime.
- Optional Reacta-Link wireless emergency for automated centralised reporting.
- Optional Reacta-Control wireless emergency for automated centralised reporting.

### CONTROL

- Optional compatibility with a range of dimming systems including DALI, DSI and Switch Dimming
- Optional Integral R25 microwave presence and bright out sensor

- Optional Integral R25W wireless microwave presence and bright out sensor
- Optional integral Reacta-Link for integration with Reacta-Link wireless installations
- Optional integral Reacta-Control for integration with Reacta-Control wireless installations

### INSTALLATION

- Suitable for surface installation
- Retrofit in existing luminaires
- Suitable for rear cable entry only

### VARIATIONS

- Available with a wide range of colour temperatures and renderings
- Available in a range of lumen outputs
- Available in white, black or grey finishes

---

## IMAGES

---

### PRODUCT IMAGES



Amenity Exterior With Black Grille



Amenity Exterior With White Grille

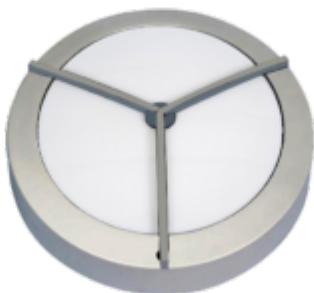

Amenity Exterior With Silver Grille

### PROJECT IMAGES



TECHNICAL

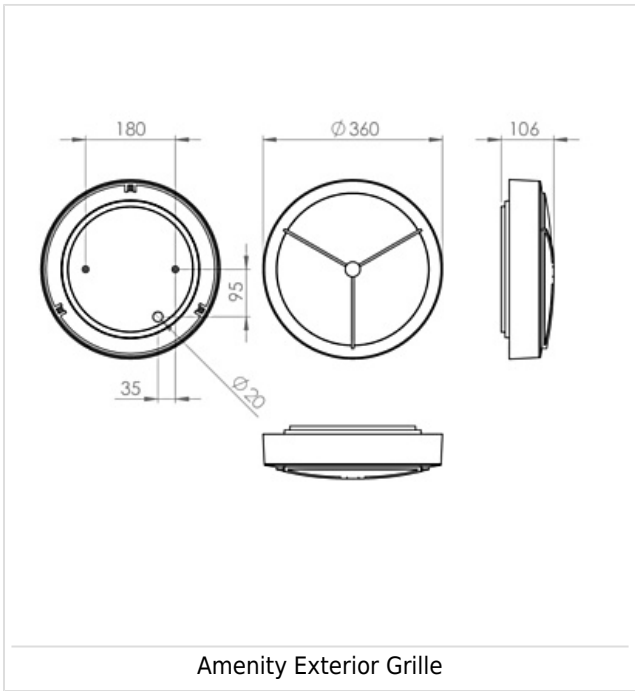

---

## WARRANTY

---

At Dextra our commitment to service has been at the forefront throughout our history spanning more than forty years in the UK lighting market. Our service ethos extends beyond design and delivery, we believe supporting your installation throughout the warranty period is equally crucial, whilst the strength and longevity of Dextra Group provides peace of mind that our warranty will be supported throughout.

The Dextra range is supplied with a five year warranty commencing from the date of delivery. During the first three years defects will be repaired on site and the warranty will include both parts and labour. For the final two years drivers, emergency modules, wireless modules, sensors and LED circuits will be supplied free of charge to replace defective components, labour and other associated costs are not included.

Certain ranges and components are subject to exemptions:

- Lithium batteries are provided with a three year warranty for parts and labour. Nickel Metal Hydride and Nickel Cadmium batteries are provided with a one year warranty for parts and labour.
- Emergency luminaires including AME LED, EXI LED, EXI2 LED, EXI Track, HBE LED, HBE2 LED, OAT2 LED, OEZ LED and Twinspot with Nickel Metal Hydride batteries are supplied with a one year warranty for parts and labour. Lithium variants of these ranges are supplied with a three year warranty for parts and labour with the exception of the AME2, EXI3, HBE3 and TWS IP65 L7 ranges which are supplied with a one year parts and labour warranty.
- Protec Micro, PTECF7 Fire Rated Downlights, Serenus and the Opus Sconce are provided with a five year replacement luminaire only warranty. Protec FR Fire Rated Downlights are provided with a 2 year replacement luminaire only warranty.
- Controls systems such as standalone sensors, switches, marshalling boxes and cabling are provided with a one year warranty for both parts and labour. DALI control systems are provided with a two year warranty for both parts and labour.
- LEDextra ranges including Glide Power, Glide Mini, Glide RGBW, Colour Glide, Glide In Ground, Glide Pixel and AluLED ranges are supplied with a three year parts or replacement luminaire only warranty.
- LEDEX ranges are supplied with a three year replacement luminaire only warranty.

All warranties are subject to correct use of the product and will be invalidated by misuse, for example incorrect installation, unsuitable environmental conditions or incorrect maintenance. It is the duty of the customer to ensure that all the fault lies with the luminaire prior to requesting replacement parts or site repairs. In the event that no defect is found with the product our costs for attending site will be recharged to the customer and credit will not be issued against returned products. No consequential losses incurred resulting from any defect with our product will be reimbursed.

Given the nature of LED technology a small percentage of LEDs may fail during the lifetime of a luminaire, this does not cause a reduction in lumen output. As such LED luminaires are only deemed to be faulty for warranty purposes when in excess of ten percent of LEDs have failed in a single luminaire

On site repair of products under warranty will be undertaken during normal working hours, 9am to 5pm Monday to Friday, and will require unrestricted access to luminaires. Where required Dextra will provide access equipment to carry out repairs at height, should luminaires have been installed in locations where reasonable provision for maintenance access has not been made we reserve the right to supply replacement product only.

If you require any assistance with regards to our products please contact our Customer Services department on 01747 858100.

[DOWNLOAD WARRANTY PDF](#)

## ORDER CODES

### LUMINAIRE

Code	Description	Circuit Wattage	Llm/W
AMEX L8 GW	Amenity Exterior, 464llm, Grille, White Opal, Colour 84	7.1W	65
AMEX L8 GB	Amenity Exterior, 464llm, Grille, Black Opal, Colour 84	7.1W	65
AMEX L8 GS	Amenity Exterior, 464llm, Grille, Silver Opal, Colour 84	7.1W	65
AMEX L15 GW	Amenity Exterior, 861llm, Grille, White Opal, Colour 84	9.5W	90
AMEX L15 GB	Amenity Exterior, 861llm, Grille, Black Opal, Colour 84	9.5W	90
AMEX L15 GS	Amenity Exterior, 861llm, Grille, Silver Opal, Colour 84	9.5W	90
AMEX L20 GW	Amenity Exterior, 1,148llm, Grille, White Opal, Colour 84	13.4W	85
AMEX L20 GB	Amenity Exterior, 1,148llm, Grille, Black Opal, Colour 84	13.4W	85
AMEX L20 GS	Amenity Exterior, 1,148llm, Grille, Silver Opal, Colour 84	13.4W	85
AMEX L30 GW	Amenity Exterior, 1,719llm, Grille, White Opal, Colour 84	22.3W	77
AMEX L30 GB	Amenity Exterior, 1,719llm, Grille, Black Opal, Colour 84	22.3W	77
AMEX L30 GS	Amenity Exterior, 1,719llm, Grille, Silver Opal, Colour 84	22.3W	77

### DIMMING

Code	Description
A	DALI Digital Addressable Lighting Interface
S	Switch Dimming
D	DSI Digital Dimming
C	Bi-Level Dimming For Standalone Switched Sensor

### CONTROL

Code	Description
R25E	Reacta 25, Presence & Bright Out, On / Off, 2.5-4M
R25C*	Reacta 25, Presence & Bright Out, Bi-Level Dimming, 2.5-4M
R25W	Reacta 25, Wireless, Presence & Bright Out, Dimmable, 2.5-4M
R25WE	Reacta 25, Wireless, Presence & Bright Out, On / Off, 2.5-4M
RCM	Reacta-Control Microwave Wireless, Presence, Bright Out, 2.5M-4M
RLM	Reacta-Link, Wireless, Presence, 2.5-4M
RC	Reacta-Control, Wireless Enabled Luminaire

Please click [here](#) for full details on our wireless controls.

\*Bi-Level Dimming will only dim the luminaire to 10% during absence and brightout, it will not turn the luminaire off.

### EMERGENCY

Code	Description
LE3	Lithium Standard Emergency 3 Hour
LS3	Lithium Selftest Emergency 3 Hour
LA3	Lithium Autotest Emergency 3 Hour
LA3RC	Lithium Reacta-Control Emergency 3 Hour
LSTR	Lithium Reacta-Link Emergency 3 Hour

### MISCELLANEOUS

Code	Description
C**	Select Colour Temperature and Rendering; C83, C84, C85, C865, C93, C94
NL	Night Light (non emergency variants only)