

220-240V / 50-60Hz
IP20



Terminal Labelling:	
Power	
L1	Switched Live
E	Earth
N	Neutral
Emergency	
L2	Unswitched Live
DA/AT3	DALI Autotest
DA/AT3	DALI Autotest
Dimming	
-D1/DA	Analogue/DSI/DALI
+D2/DA	Analogue/DSI/DALI
L3	Switch Dim / Corridor Function

WARNING: Luminaire must be earthed. Risk of electric shock from LED boards if operated with cover removed. Installation / operation outside of luminaires intended scope invalidates warranty. Suitable only for domestic / light industrial / industrial applications within the scope of EN55015. Tested to compliance with BSEN 60598: specification for general requirements and tests. Must be installed by a suitably qualified person in accordance with all relevant legislation. Ambient operating temperature of 0°C to 25°C. If maximum operating temperature is exceeded luminaire will automatically dim / switch off. Terminal blocks are rated to 16A unless stated otherwise. The light source contained in this luminaire shall only be replaced by the manufacturer itself or his service agent or a similar qualified person. **LUMINAIRES WITH EMERGENCY PACK:** When supply is isolated battery output terminals may be live if battery is connected. Isolate mains and battery before servicing. Emergency luminaires require unswitched live connection taken from same phase as switched supply. When unswitched supply is connected status indicator illuminates green, when unswitched supply is disconnected indicator extinguishes and luminaire operates in emergency mode. 24 hour charge period required before undertaking full discharge test. Emergency test sheets provided should be used to record all emergency tests. Batteries should be replaced when 3 hour duration is not met. Excessive switching of permanent live may result in premature battery failure. Battery electrolyte can be harmful to eyes / open wounds, do not puncture, if electrolyte touches skin / eyes flush with water. Do not incinerate batteries.

1. Remove screws

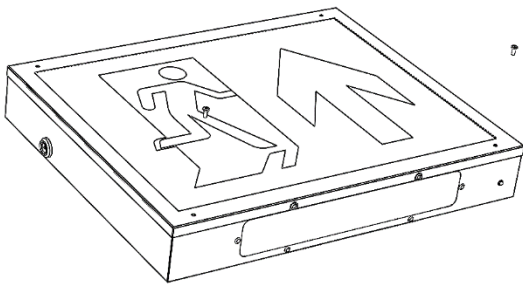

2. Remove frame and legend

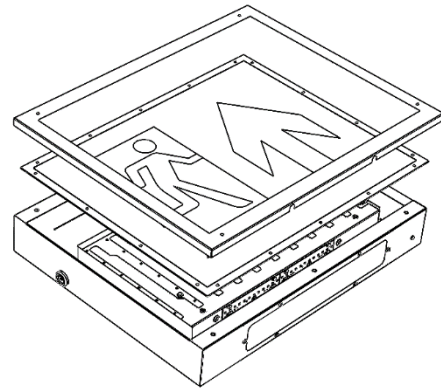

3

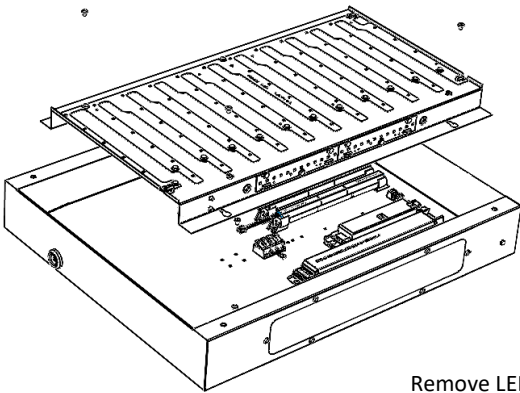

Remove LED tray to access housing

4. Rear fixings

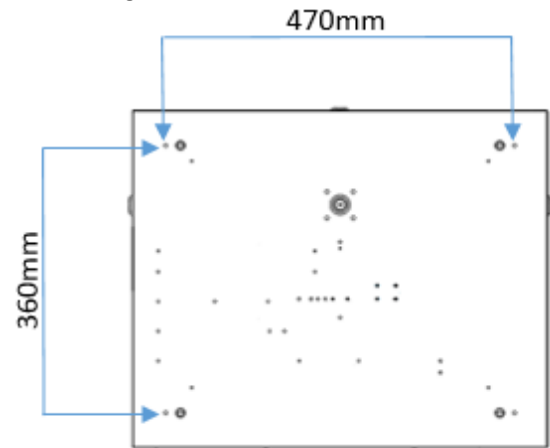

5. Top (suspended) fixings

Fix the suspension points to the ceiling at the specified centres

Fit suspension clutch as shown

460mm

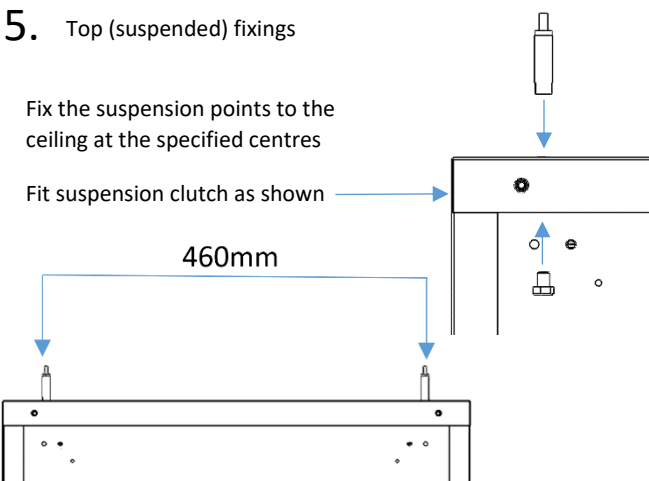

6.

Pass suspension wire through the clutch and adjust to the required height. Cut off excess suspension cable.

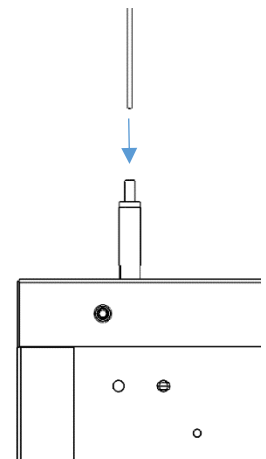

EXIXL Installation

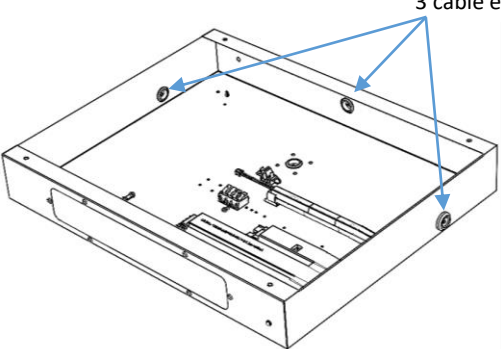
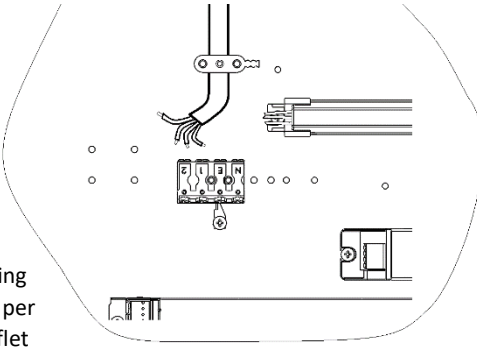
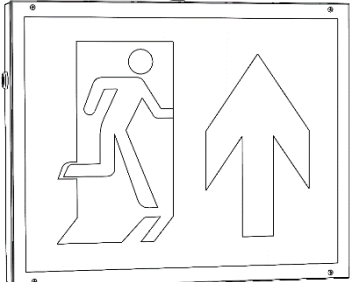
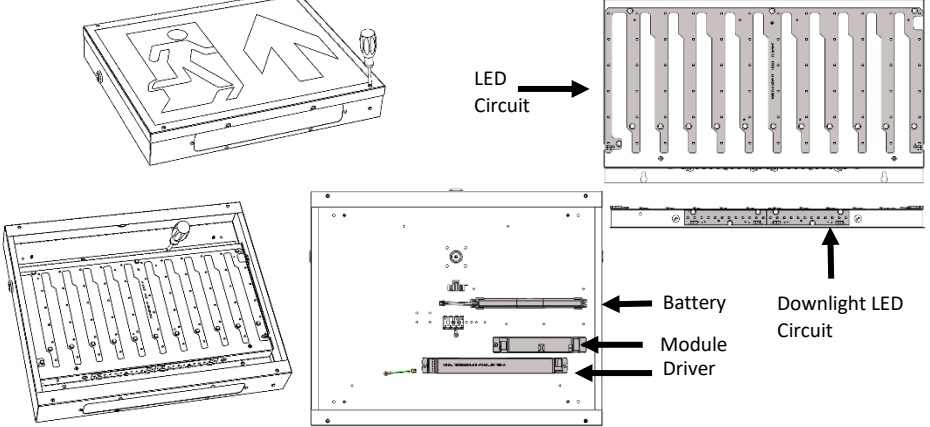
<p>7.</p>  <p>3 cable entry options</p>	<p>8.</p>  <p>Connect incoming power cable as per diagram on leaflet and use cable clamp kit provided.</p>
<p>9. Re-assemble fitting</p>  <p>Locate legend in-between the frame and housing when replacing the frame. Fasten frame in place with original screws.</p>	<p>10.</p>
<p><u>Maintenance</u></p> <ol style="list-style-type: none"> 1 Disconnect luminaire before undertaking any maintenance or cleaning. 2 Cleaning should be undertaken on external parts of the luminaire only using a slightly damp lint free cloth. 3 Use a pan pozi screwdriver to remove all screws from frame to access fitting. 4 To remove LED tray from housing use a pan pozi screwdriver. Use this screwdriver to remove components as well. 5 Please contact Dextra for assistance with spare component supply. 	 <p>LED Circuit</p> <p>Battery</p> <p>Module Driver</p> <p>Downlight LED Circuit</p>