

## Planum Installation

220-240V / 50-60Hz  
IP30



**Terminal Labelling:**

<b>Power</b>	
L1	Switched Live
E	Earth
N	Neutral
<b>Emergency</b>	
L2	Unswitched Live
DA/AT3	DALI Autotest
DA/AT3	DALI Autotest
<b>Dimming</b>	
-/D1/DA	Analogue/DSI/DALI
+/D2/DA	Analogue/DSI/DALI
L3	Switch Dim / Corridor Function

**WARNING:** Luminaire must be earthed. Risk of electric shock from LED boards if operated with cover removed. Installation / operation outside of luminaires intended scope invalidates warranty. Suitable only for domestic / light industrial / industrial applications within the scope of EN55015. Tested to compliance with BSEN 60598: specification for general requirements and tests. Must be installed by a suitably qualified person in accordance with all relevant legislation. Ambient operating temperature of 0°C to 25°C. If maximum operating temperature is exceeded luminaire will automatically dim / switch off. Terminal blocks are rated to 16A unless stated otherwise. The light source contained in this luminaire shall only be replaced by the manufacturer itself or his service agent or a similar qualified person. **LUMINAIRES WITH EMERGENCY PACK:** When supply is isolated battery output terminals may be live if battery is connected. Isolate mains and battery before servicing. Emergency luminaires require unswitched live connection taken from same phase as switched supply. When unswitched supply is connected status indicator illuminates green, when unswitched supply is disconnected indicator extinguishes and luminaire operates in emergency mode. 24 hour charge period required before undertaking full discharge test. Emergency test sheets provided should be used to record all emergency tests. Batteries should be replaced when 3 hour duration is not met. Excessive switching of permanent live may result in premature battery failure. Battery electrolyte can be harmful to eyes / open wounds, do not puncture, if electrolyte touches skin / eyes flush with water. Do not incinerate batteries.

1.

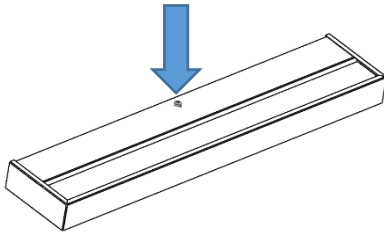

Fitting will be supplied complete. You will need to remove the wall mount bracket from the back of fitting in order to mount it to the wall. Remove the screw on the back edge of the fitting. This will release the wall mount bracket.

2.

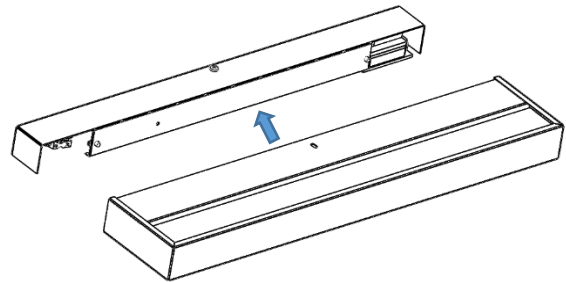

Slide the wall mount bracket out from the back of the fitting.

3.

Screw the wall mount bracket to the wall using the fixing points located between the bumper feet.

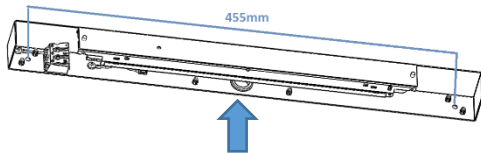

Then feed cable through the central hole and make the electrical connection to the terminal block.

4.

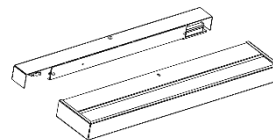

Offer the fitting back up to the wall mount bracket.

Connect the mount bracket to the fitting with the plug and socket, then earth cable to the brass tag.

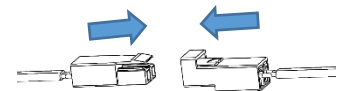

5.

Once connections have been made, slide the fitting onto the wall mount bracket. Refer to step 6 for sensor version  
Refer to step 7 for emergency version.

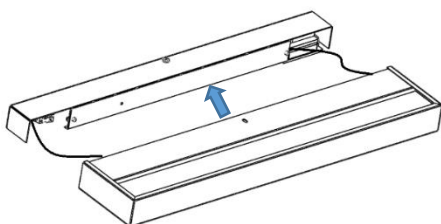

6.

**Sensor Version (Planum 500)** – ensure sensor plug and socket cable is positioned in the channel between the driver and back of the bracket before sliding fully onto bracket.

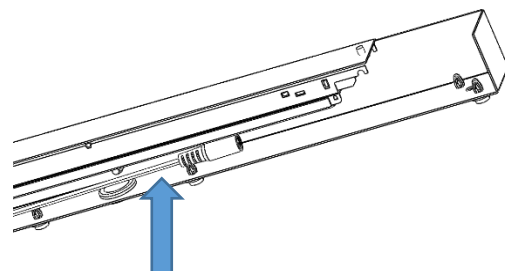

## Planum Installation

7. **Emergency Version (Planum 1500)** – Before sliding the fitting onto bracket. Insert the emergency Indicator LED into the grommet, push down until it locks in place.

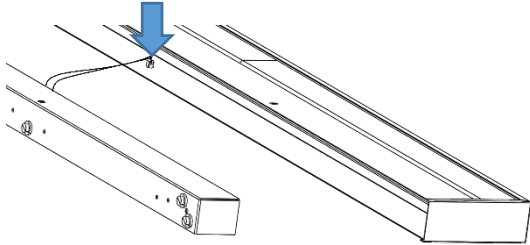

8.

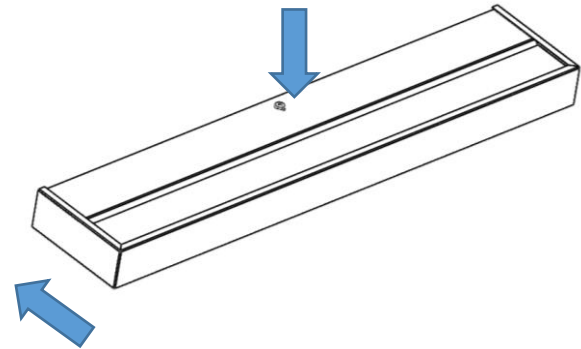

Ensure fitting is pushed flush to the wall before the fixing screw is tightened.

9.

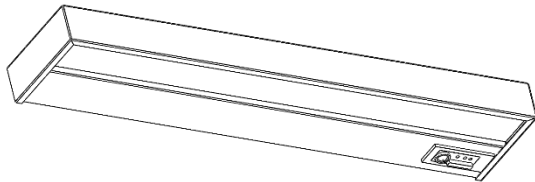

Installation is now complete.

10.

### Maintenance

- 1 Disconnect luminaire before undertaking any maintenance or cleaning.
- 2 Cleaning should be undertaken on external parts of the luminaire only using a slightly damp lint free cloth.
- 3 Using a pan pozi screwdriver remove x1 screw from fitting then slide out wall mount bracket to reveal driver.
- 4 LED circuits are non-maintainable.
- 5 Use a pan pozi screwdriver to remove driver.
- 6 Please contact Dextra for assistance with spare component supply.

