

Runway Cross Installation

220-240V / 50-60Hz
IP20



Terminal Labelling:

Power

L1 Switched Live
E Earth
N Neutral

Emergency

L2 Unswitched Live
DA/AT3 DALI Autotest
DA/AT3 DALI Autotest

Dimming

-/D1/DA Analogue/DSI/DALI
+/D2/DA Analogue/DSI/DALI
L3 Switch Dim /
Corridor Function

WARNING: Luminaire must be earthed. Risk of electric shock from LED boards if operated with cover removed. Installation / operation outside of luminaires intended scope invalidates warranty. Suitable only for domestic / light industrial / industrial applications within the scope of EN55015. Tested to compliance with BSEN 60598: specification for general requirements and tests. Must be installed by a suitably qualified person in accordance with all relevant legislation. Ambient operating temperature of 0°C to 25°C. If maximum operating temperature is exceeded luminaire will automatically dim / switch off. Terminal blocks are rated to 16A unless stated otherwise. The light source contained in this luminaire shall only be replaced by the manufacturer or his service agent or a similar qualified person. **LUMINAIRES WITH EMERGENCY PACK:** When supply is isolated battery output terminals may be live if battery is connected. Isolate mains and battery before servicing. Emergency luminaires require unswitched live connection taken from same phase as switched supply. When unswitched supply is connected status indicator illuminates green, when unswitched supply is disconnected indicator extinguishes and luminaire operates in emergency mode. 24 hour charge period required before undertaking full discharge test. Emergency test sheets provided should be used to record all emergency tests. Batteries should be replaced when 3 hour duration is not met. Excessive switching of permanent live may result in premature battery failure. Battery electrolyte can be harmful to eyes / open wounds, do not puncture, if electrolyte touches skin / eyes flush with water. Do not incinerate batteries.

1.

Suspension fixing points are at 950mm centres crossing at the midpoint.

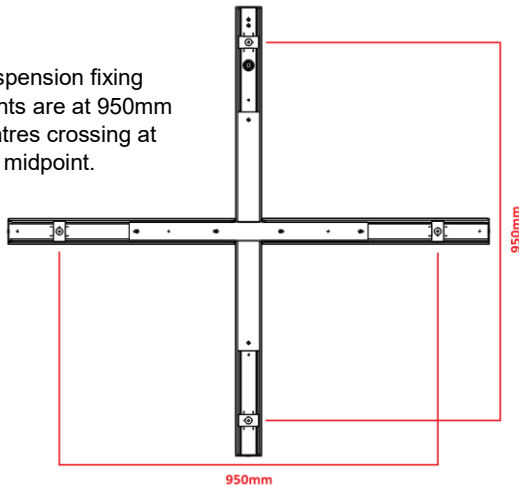

2.

Attach the suspension wire the spring brackets ready to be attached to the trunking.

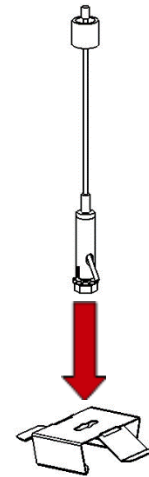

3.

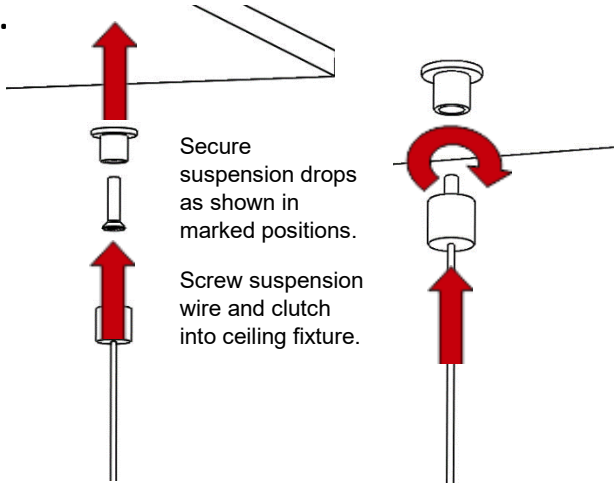

Secure suspension drops as shown in marked positions.

Screw suspension wire and clutch into ceiling fixture.

4.

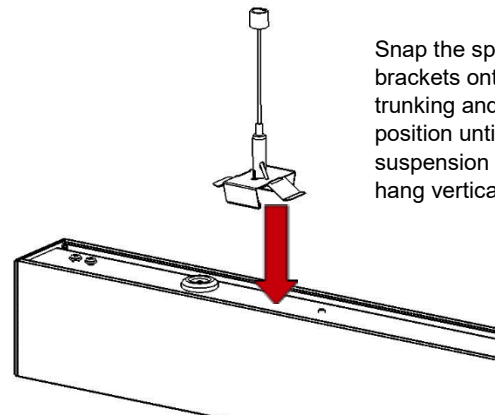

Snap the spring brackets onto the trunking and adjust position until the suspension wires hang vertically.

5.

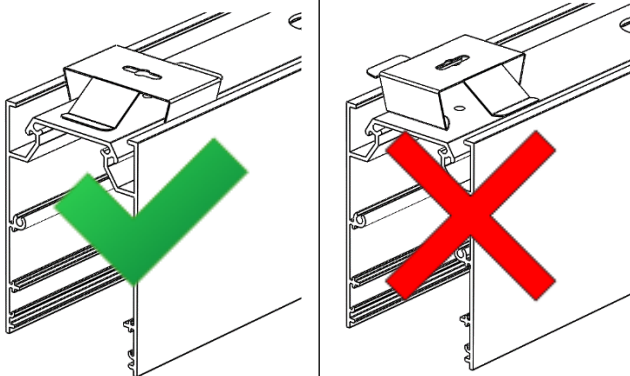

6.

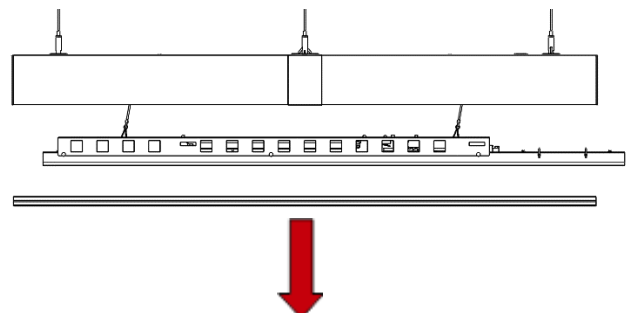

Remove the long 1200mm section of diffuser and drop the gear tray onto its tethers to access the starter bracket in the trunking.

Runway Cross Installation

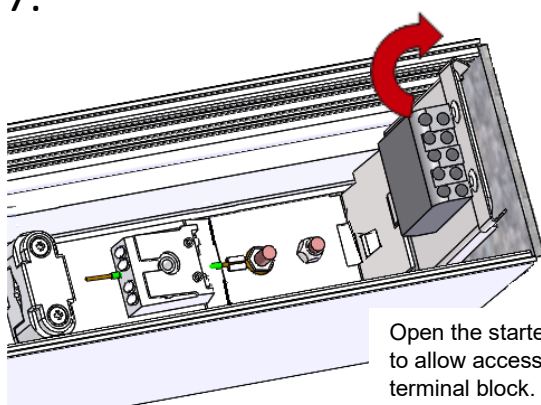
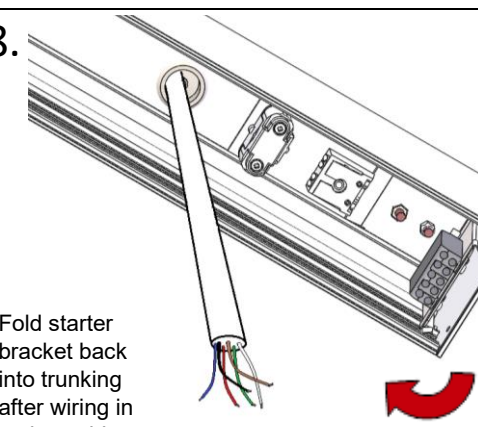
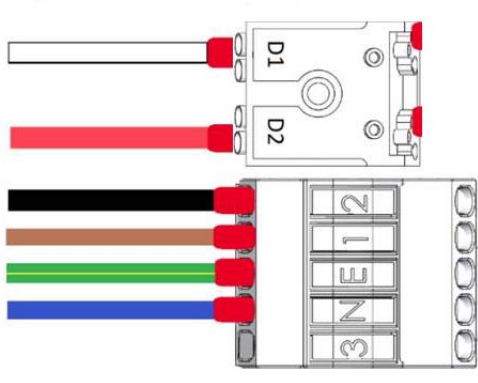
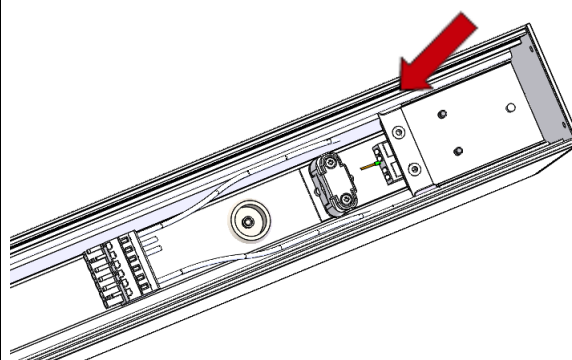
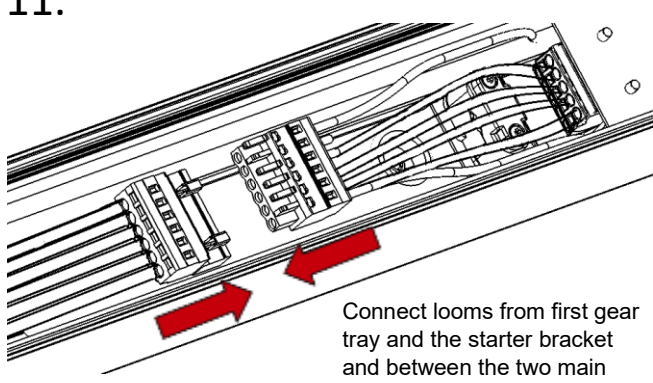
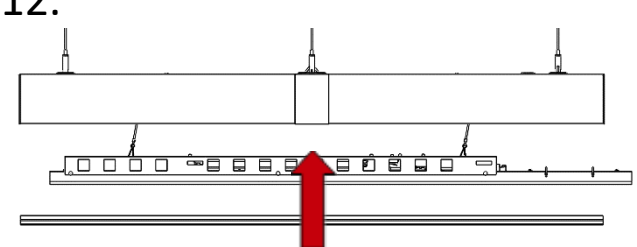
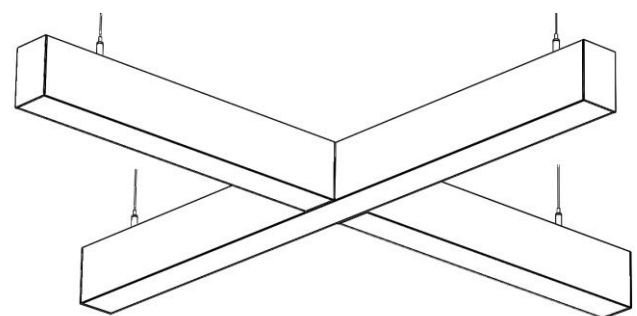
<p>7.</p>  <p>Open the starter bracket to allow access to the terminal block.</p>	<p>8.</p>  <p>Fold starter bracket back into trunking after wiring in mains cable.</p>
<p>9.</p> 	<p>10.</p> <p>Push bracket trunking to lock in place.</p> 
<p>11.</p>  <p>Connect looms from first gear tray and the starter bracket and between the two main gear trays if applicable.</p>	<p>12.</p>  <p>Replace gear tray (ensuring no wires are trapped) and diffuser.</p>
<p>13.</p> 	

Runway Cross Installation

Maintenance

- 1 Disconnect luminaire before undertaking any maintenance or cleaning.
- 2 Cleaning should be undertaken on external parts of the luminaire only using a slightly damp lint free cloth.
- 3 Use a flat headed screwdriver to remove diffuser.
- 4 Remove gear tray from housing.
- 5 Remove plastic rivets to separate the two gear trays.
- 6 Use a pan pozi screwdriver to remove components.
- 7 Please contact Dextra for assistance with spare component supply.

